

Installation and Operating Instructions

TRAIL-Control - Manufacturer -

Release 03-2001

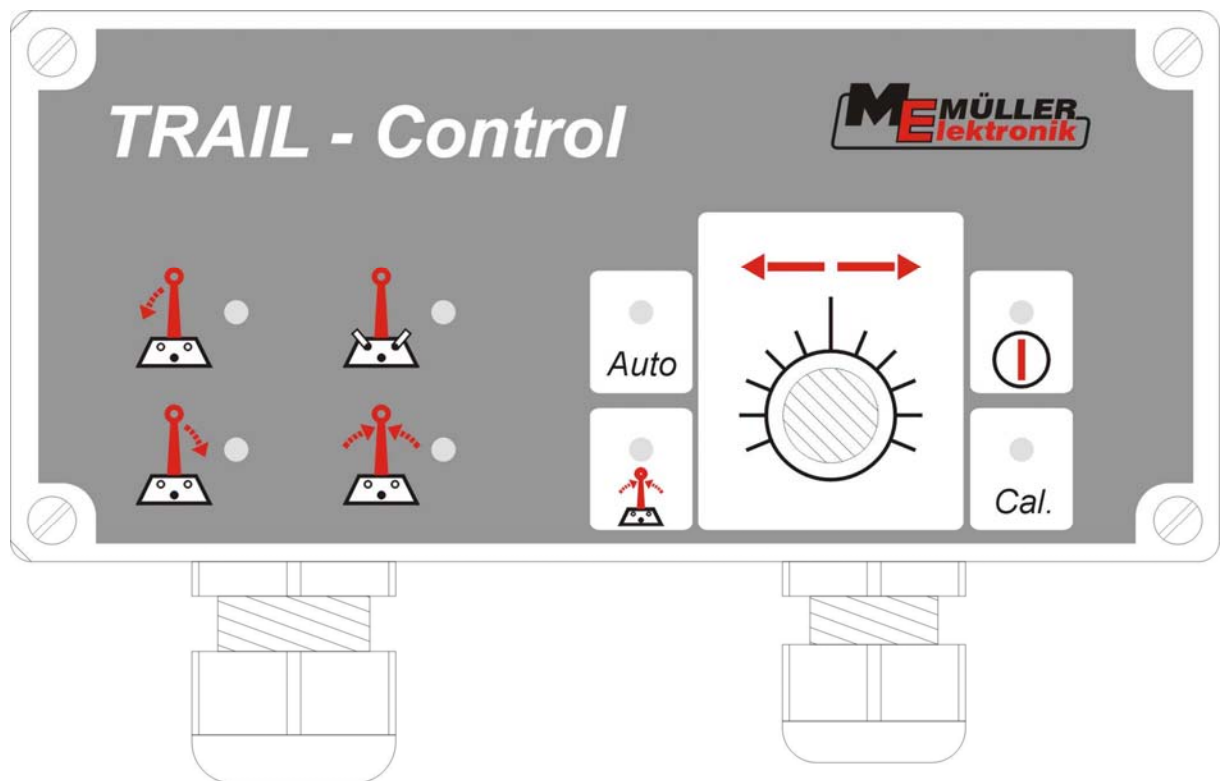

Contents

1.	Overview	5
2.	Security.....	6
2.1.	Disclaimer:	6
2.2.	Safety precautions	6
3.	Mounting Instructions - TRAIL-Control.....	7
3.1.	Computer	7
3.2.	12V Power Supply	7
3.3.	Switching Box Implement.....	7
3.4.	Potentiometer (Poti)	8
3.4.1.	Mounting of the Tractor Potentiometer.....	8
3.4.1.1.	Trailer Coupler	8
3.4.1.2.	Hitch.....	9
3.4.2.	Mounting of Implement Potentiometer	10
3.4.2.1.	Pole Steering	10
3.4.2.2.	Wheel Steering	11
3.4.2.3.	Electrical Connection of the Potentiometers.....	12
3.4.2.4.	Potentiometer check with multi meter	13
3.5.	Lock sensor	14
3.6.	Hydraulic System	15
3.7.	Control Function Check	16
3.7.1.	Check without hydraulic system	16
3.7.2.	Check with hydraulic system	16
4.	Operating Instructions.....	18
4.1.	System Set-up.....	18
4.2.	Description of the Keys.....	18
4.2.1.	On/Off Key.....	18
4.2.2.	Automatic / Manual Key	18
4.2.3.	Centre Position / Manual Key	19
4.2.4.	Calibration Key	19
4.3.	The Manual Control Turnkey.....	19
4.4.	The Display Devices	20
4.4.1.	Control Left Lamp.....	20
4.4.2.	Control Right Lamp	20
4.4.3.	Centre Position Lamp.....	20
4.4.4.	Lock Indication Lamp	20
5.	Basic Tuning	21
5.1.	Centre Position	21
5.1.1.	Learning centre position.....	21
5.1.2.	Adjust manual control key:	22
5.2.	Learning Final Stops	23
5.3.	Return to basic tuning	24
6.	Maintenance.....	24
6.1.	Computer	24
6.2.	Sensors	24
7.	Trouble shooting.....	25
8.	Appendix	27

8.1. Hydraulic System Open Centre27
8.2. Hydraulic System Open Centre with "N" as Flow Through28
8.3. Hydraulic System Closed Centre29
8.4. Hydraulic System Closed Centre and "N" as Flow Through30
8.5. Hydraulic system Load sensing.....31
8.6. Locking Screw for Valve32
8.7. Lock valve33

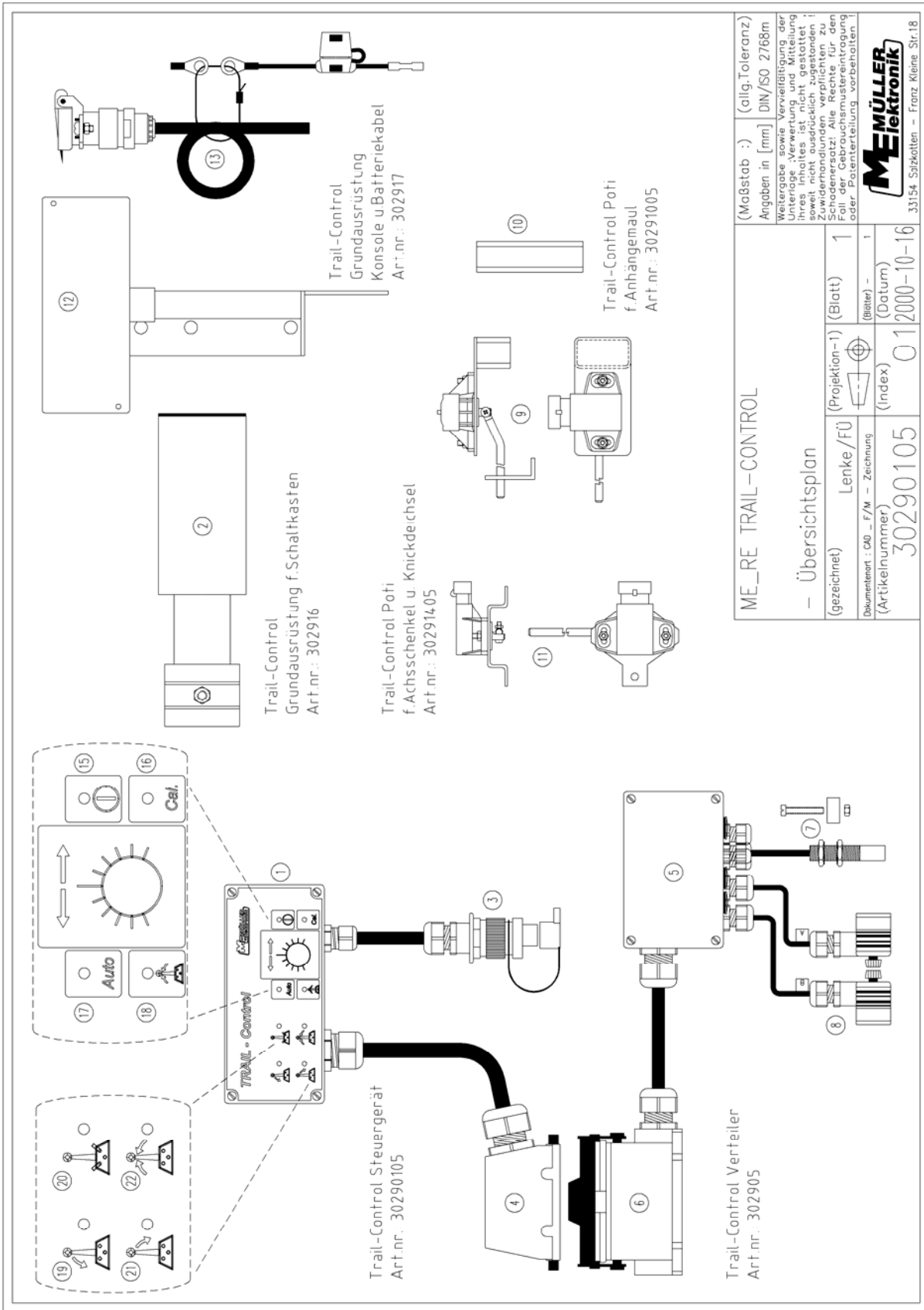

ME_RE TRAIL-CONTROL		(Maßstab :) (allg. Toleranz)	
- Übersichtsplan		Angaben in [mm] DIN/ISO 2768m	
(gezeichnet)	Lenke/Fü	(Projektion-1) (Blatt)	1
Documentat : CAD - F/M - Zeichnung	(Artikelnummer)	(Blätter - Datum)	1
30290105	012000-10-16		



33154 Spitzkotten - Franz Kleine Str.18

1. Overview

- [1] TRAIL - Control Computer
- [2] Mounting console for switching box S
The computer is mounted to the console and fastened at the switching box.
- [3] Plug for power supply 12V
- [4] Machine-coupling
Connection to the distributor
- [5] Switching box
Houses the sensor and actuator connections of the implement
- [6] Socket for switching box
Connection to TRAIL-Control Computer
- [7] Lock sensor with magnet
Sensor recognises active lock in case magnet is in position in front of it.
- [8] Plug for hydraulic valve
- [9] Potentiometer (Poti) for Remote Control Cable
- [10] Mounting angle for Potentiometer and Remote Control Cable
- [11] Potentiometer drawbar
- [13] Console for post supply, in case no mounting console is present
- [14] Battery cable
- [15] Manual control
- [16] "On/Off" Key with control lamp
- [17] "Calibrate" Key with control lamp
- [18] "Automatic" Key with control lamp
- [19] "Centre Position" Key with control lamp
- [20] "Control left" control lamp
- [21] "Lock indication" control lamp
- [22] "Control right" control lamp
- [23] "Centre Position" control lamp

2. Security

2.1. Disclaimer:

The System is specified only for agricultural use. Use outside this area is regarded as unspecific.

The manufacturer does not accept liability for damages to persons or property resulting from unspecific use. In such cases all risks are in responsibility of the user.

Specified implementation also includes adhering to the operation and maintenance conditions stipulated by the manufacturer.

The relevant accident prevention regulations as well as other recognised safety, industrial medical and road traffic rules must be adhered to. Neither does the manufacturer accept liability in cases where independent modifications have been made to the System.

2.2. Safety precautions

Warning!



**Always watch for this symbol to point out important safety precautions.
It means attention! Become alert!
Your safety is involved.**



Always read this operators manual before using the equipment.

3. Mounting Instructions - TRAIL-Control

3.1. Computer

Mount the computer with the enclosed console (article number 302916) to the switching box S console. Please note, that there should be a distance of 1m to all broadcast devices and antennas.

In case there is no switching box S console you can obtain a basic mounting supply with article number 302917. It consists of one console and one battery cable.

For old housing systems until '93 article number 302915 is to be used.

3.2. 12V Power Supply

The TRAIL-Control is being power supplied through the switching box of the implement. In case no socket is available, you can obtain a special battery cable with article number 312154 .

When mounting, please obey the following:

- The battery cable is to be connected directly to the battery of the tractor.
- Do not connect any additional device to this socket.
- Secure the 12V socket with a 16A melting fuse to be found in the brown line of the line connector.
- Colours of the lines:
 - brown = +12 Volt
 - blue = Ground
- The minus pole must be connected to the frame of the tractor.

3.3. Switching Box Implement

The switching box is to be mounted to the plate of the implement. The hydraulic valve plugs (“A” and “B”) are to be connected to the appropriate valves (see chapter 3.6).



Warning!

The included warning stickers are to be placed well visible into the danger zone.

3.4. Potentiometer (Poti)

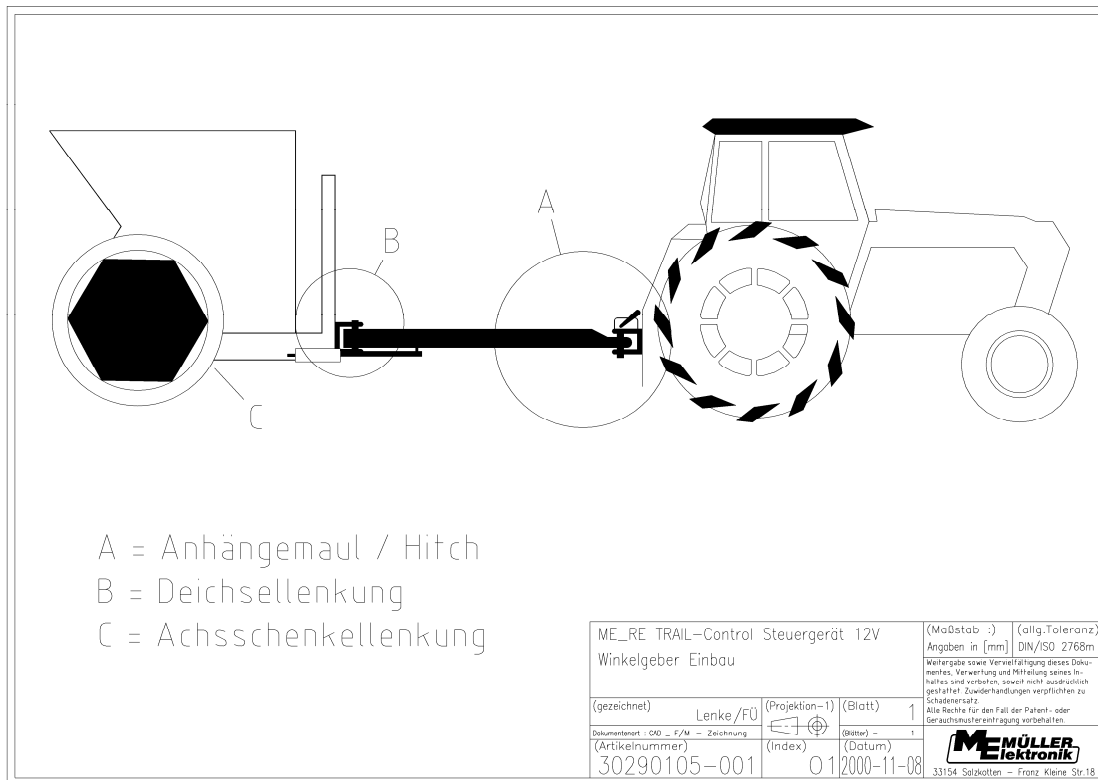

3.4.1. Mounting of the Tractor Potentiometer

3.4.1.1. Trailer Coupler

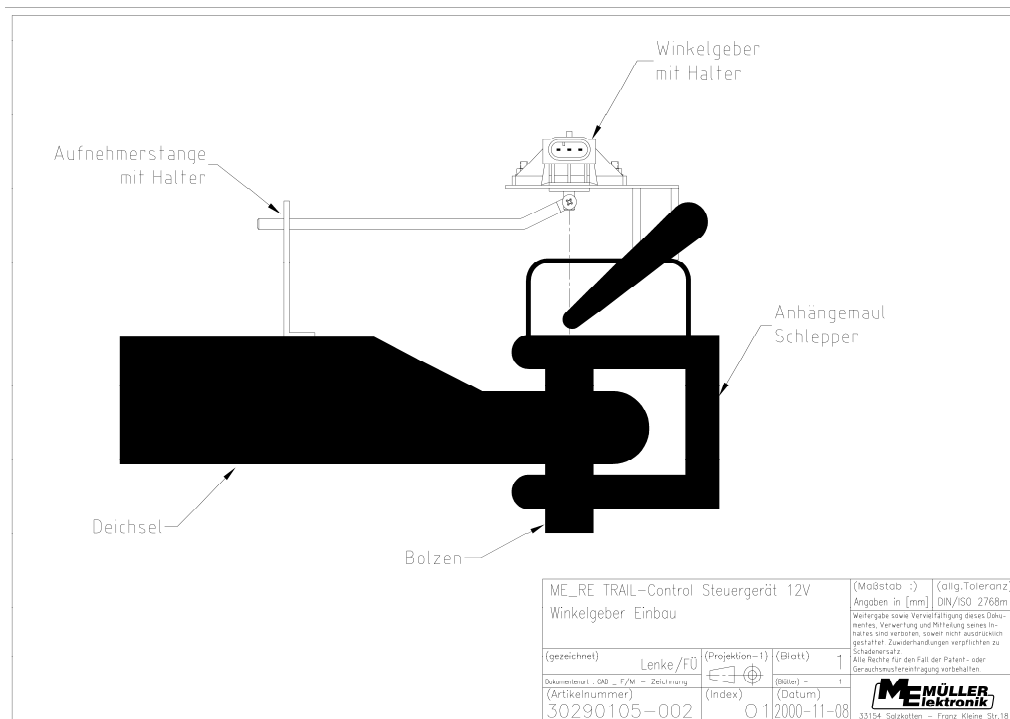

Installation:

- Fix the holder (version with wing screw) on the trailer-coupler
- Put on the angle transmitter and fix it with the wing screw. The axis has to be in the centre of the bolt
- Bend the bar so that it can run parallel to the drawbar through the angle support
- Fix the angle support on the drawbar. The bar should run about 10 cm through the angle support.

Warning: If the 10 cm are undershot it can happen that the bar falls off during the drive

- Fix the mounting angle on the drawbar. This serves for the absorption of the angle transmitter when the machine is moved from the tractor.

3.4.1.2. Hitch

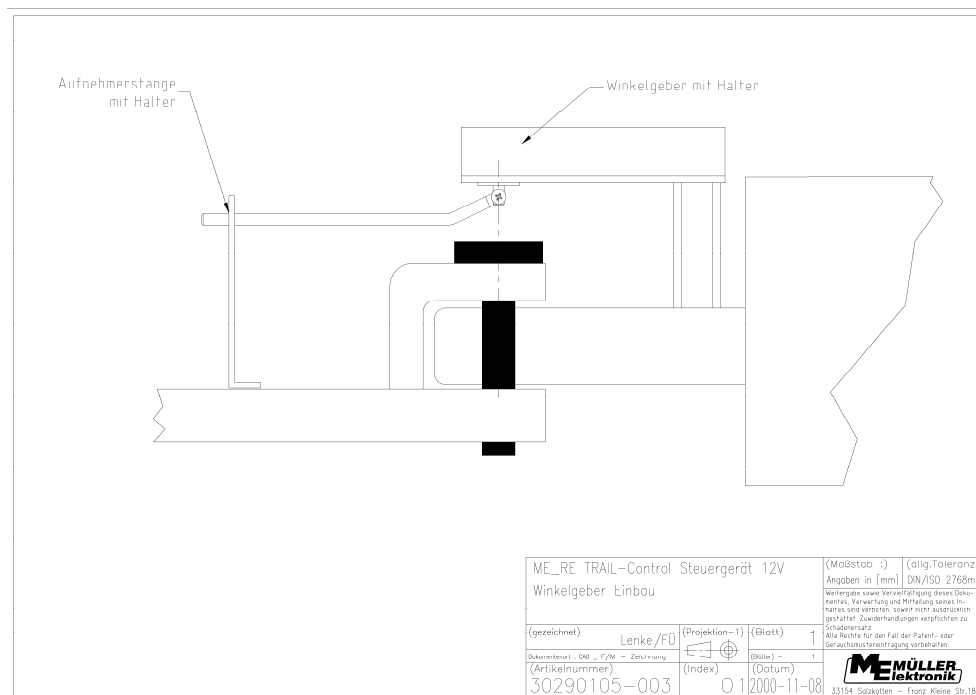

Installation:

- Fix the holder (version with wing screw) on the drawbar.
- Put on the angle transmitter and fix it with the wing screw. The axis has to be in the centre of the bolt
- Bend the bar so that it can run parallel to the mounting mechanism through the angle support
- Fix the angle support on the mounting mechanism. The bar should run about 10 cm through the angle support.

Warning: If the 10 cm are undershot it can happen that the bar falls off during the drive

- Fix the mounting angle on the drawbar. This serves for the absorption of the angle transmitter when the machine is moved from the tractor.

3.4.2. Mounting of Implement Potentiometer

3.4.2.1. Pole Steering

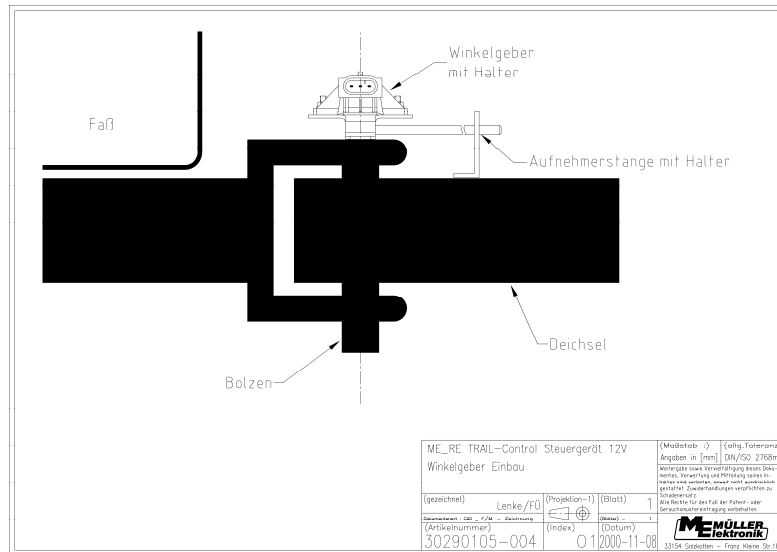

Installation:

- Fix the angle transmitter with the holder over the center on the frame. The axis must be in the center over the pivot point. The flat side must point to the connection plug.
- Bend the bar so that it run parallel to the drawbar through the angle support.
- Fix the angle transmitter on the drawbar. The bar should run at least 2 cm through the angle support.

3.4.2.2.

Wheel Steering

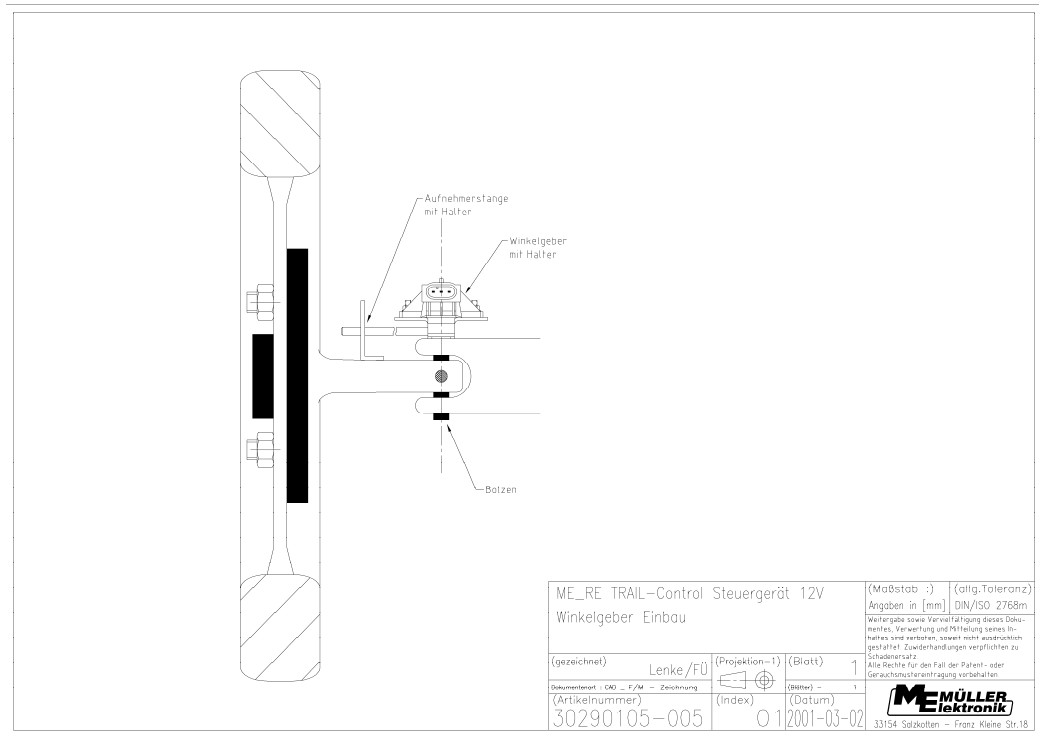

Installation:

- Fix the angle transmitter with the holder over the center on the wheel. The axis must be in the center over the pivot point. The flat side of the axis must point to the connection plug.
- Bend the bar so that it run parallel to the axis through the angle support.
- Fix the angle transmitter on the axis. The bar should run at least 2 cm through the angle support.

3.4.2.3. Electrical Connection of the Potentiometers

The connection to the switching box is through a 3-wire cable. The colours of the wires are white, green, and brown. Connect the cables to the connectors "Poti Deichsel" and "Poti Schlepper" obeying the proper colours.



Caution!

The polarity of the potentiometers is very important. If the wires are mixed up the potentiometer may be destroyed.

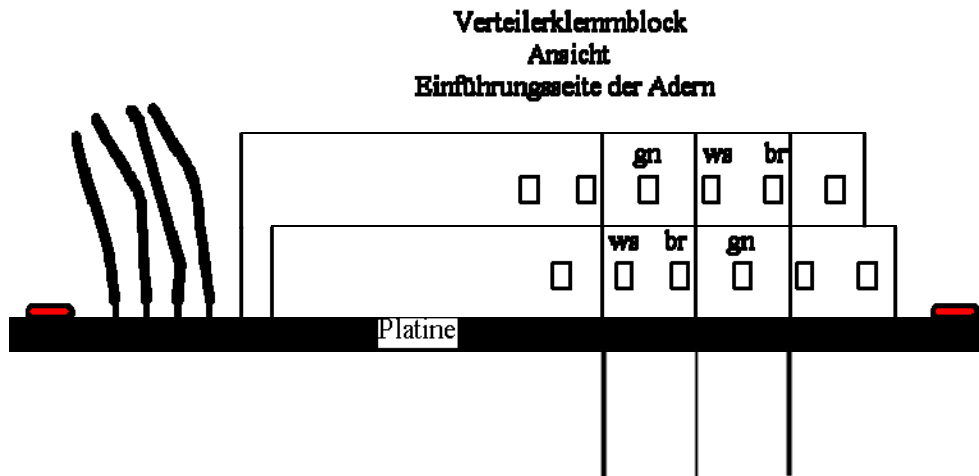

Some potentiometers are equipped with different cables with varying colours. See the following table before connecting the wires:

	Switching box connector	Colour of the wire
+ 12V	br	Brown
Signal	gn	Green/Yellow
Ground	ws	Blue

3.4.2.4. Potentiometer check with multi meter

Both potentiometers can be examined with a multi meter. The voltage can be measured in the switching box at the connector of the potentiometers. The TRAIL-Control computer must be switched on.



Attention!

The hydraulics must be switched off to prevent erratic movement of the machine.

The voltages are the same for both potentiometers. The following table shows which voltages can be measured at the different connectors.

+ Connector of the multi meter at	Ground connector of the multi meter at	Result
Brown	White	12 – 13,8V
Green	White	In centre position about 2.3 –2.6V. If the potentiometer is turned the voltage increases in one direction until 4.8V are reached. In the other direction the voltage decreases until 0.5V are reached. If the voltage jumps in the normal working area, the potentiometer is defective and must be replaced.

When checking the voltage at centre position, this should be watched several seconds without touching the potentiometer. If the voltage moves more than $\pm 0.05V$ during this time, the potentiometer is defective and must be replaced.

3.5. Lock sensor

If moving on public roads the steering must be locked mechanically in the centre position. The lock is being controlled by the TRAIL - Control lock sensor. Trail - Control does not work if the steering is locked. Switching on is only possible when the locking bolt is removed. As long as the steering is locked, all lamps will be lit. When the start key is released the unit will be switched off again.

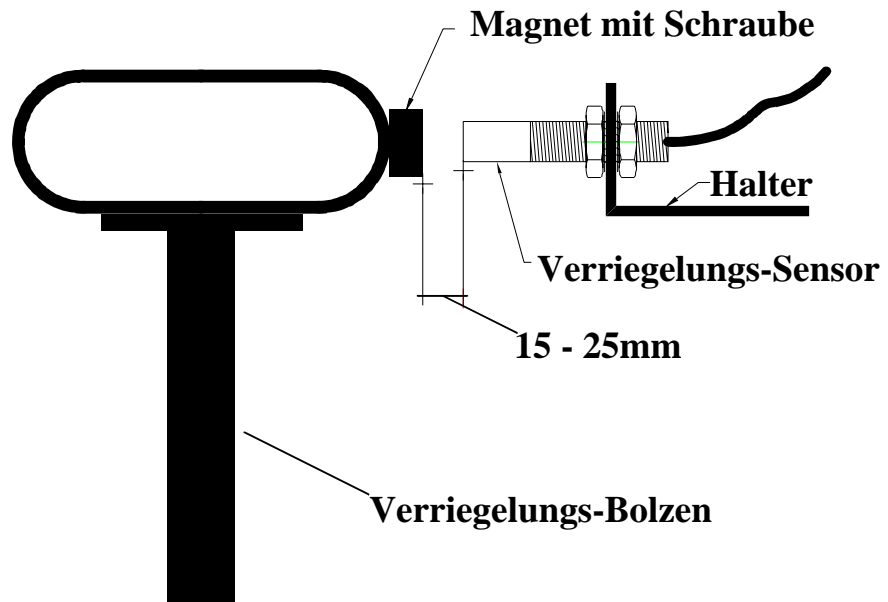

3.6. Hydraulic System

The hydraulic system of the tractor must guarantee a throughput of at least 25 l/min. If throughput is less, TRAIL - Control does not work properly since the control speed is too low.

⚠ Because of the sensitivity of the hydraulic system to dirt in the oil it is necessary to use a pressure filter (NAS class 6). The tubes connected to the tractor should have the following data.

	max. oil velocity	Size of the tube (at 70 l/min pump performance)
Connector	5,5 m/s	DN 16
Pressure	2 m/s	DN 25
Tank		

To connect the hydraulic system of the tractor to the implement please obey the attached connecting instructions. It is very important to connect the high pressure hose of the tractor with the connector "P" and the return with the connector "T" of the valve. Make sure the valve is prepared for the used hydraulic type (see chapter 8).



The plug "A" must be connected to the magnet at the hydraulic connector "A" and the plug "B" to the magnet at the hydraulic connector "B". The hydraulic hoses should be fitted to the cylinder as shown in the figure below.

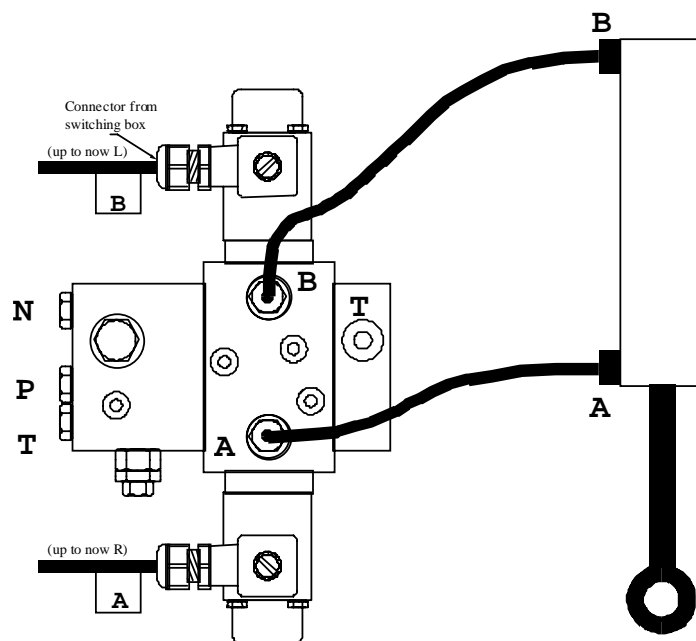





If it is necessary to change the working direction, only the hoses may be changed. The electrical connections must be always at the same place as described in the picture above. This is important because of the different current the coils work with.

3.7. Control Function Check

3.7.1. Check without hydraulic system

Before mounting the remote control cable of the tractor potentiometer the proper function of the TRAIL - Control should be checked. Please proceed as follows:

- > **switch off hydraulic system.**
- > switch on TRAIL-Control using the  - key.
- > switch on automatic mode using the  - key.
- > now turn the tractor potentiometer to a right turn. Check, if the  - lamp indicates the proper control.
- > now turn the tractor potentiometer to a left turn. Check if  - lamp is on.

If the TRAIL - Control does not show any reaction to the movements of the tractor potentiometer, please check the connection in the switching box (tractor potentiometer to the connectors "Poti tractor" and implement potentiometer to the connectors "Poti drawbar")

3.7.2. Check with hydraulic system

Mount the remote control cable of the tractor potentiometer to the tractor and place the tractor and the implement in line.



Check the hydraulic system connections. The high pressure hose must be connected to the connector "P" and the return with the connector "T" of the valve.



CAUTION!

No person is allowed to be in the reach of the moving parts of the tractor and the implement. The implement must be able to move into both final stops.

Proceed as follows:

- > learn centre position (see chapter 5.1.1) without hydraulics switched on. The tractor and the implement must not be lined up. The actual position will be saved as centre position.
- > switch on hydraulic system.
- > turn manual control  to centre position.
- > switch on TRAIL - Control with the -key.
- > press -key.

Implement and tractor should stay as they are. If not please check the following reasons.

1. case:

The implement moves to one final position: the hydraulic connectors are mixed up. Please check chapter 3.6.

2. case:

The implement remains in line with the tractor or moves slightly from side to side. Now switch on the function "centre position" using the -key. If the implement now moves to one final position, please check the mounting of the rear potentiometer.

If you had no problems so far, switch to "Manual Control" by pressing again the -key.

Now turn the manual control key  to the right until the steering moves. If the implement ^{now} moves to the right, you can be sure the control works properly. Turning the manual control key to the left should move the implement to the left.

If the implement does not respond in this manner, please start the check again.

4. Operating Instructions

4.1. System Set-up

Connect the implement connector with the switching box of the implement and the power supply with the 12 V socket.

The device is being switch on with the  - key. If switch-on is not possible, please check the lock of the steering. You must remove the lock prior to operate TRAIL - Control.

If you still have problems please check the appropriate paragraphs in the trouble shooting chapter.

4.2. Description of the Keys

4.2.1. On/Off Key

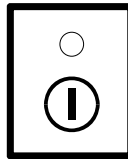

Pressing the key once should switch on the TRAIL - Control. A second key press, at least of 500 msec duration switches off the device. The control lamps act accordingly.

4.2.2. Automatic / Manual Key

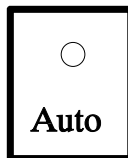

This key switches on the automatic mode, displayed by the intrinsic control lamp. The controller is now active and the implement will be lead in the trail of the tractor.

If the key is pressed again, the lamp is switched off and the mode “manual” is turned on. Now the implement reacts only on turning the manual control turnkey. Dependant on the angle the manual control turnkey is turned, the implement moves to one side. Pressing the key once more, the mode “automatic” is switched on again. Optional the key “centre position” can be pressed to switch to mode “centre position”.

4.2.3. Centre Position / Manual Key

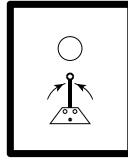

The function "centre position" is activated with this key. The control lamp displays the activated mode. The steering is being brought into centre position and can be locked now. You can use this function also to deactivate the controller.

If the key is pressed again, the lamp is switched off and the mode "manual" is turned on. Now the implement reacts only on turning the manual control turnkey. Dependant on the angle the manual control turnkey is turned, the implement moves to one side. Pressing the key once more, the mode "centre position" is switched on again. Optional the key "automatic" can be pressed to switch to mode "automatic".

4.2.4. Calibration Key

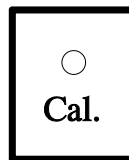

This key is not active in normal operating mode. In combination with other keys and different variations of switch-on procedures it is possible to handle special tunings.

4.3. The Manual Control Turnkey

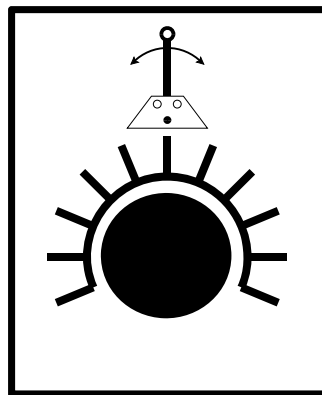

In manual mode and limited in automatic mode (dependant on the type machine) the manual control turnkey serves as a correction if working on hilly fields. It supports also the ability to follow a different trail (other than the tractor's). In addition, in calibration mode it is possible to fine-tune the controller with this key.

Please note, that in normal working mode the turnkey should be in centre position.

4.4. The Display Devices

In addition to the control lamps in the keys the TRAIL-Control has 4 lamps to display certain modes of the device.

4.4.1. Control Left Lamp

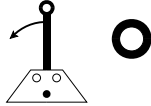

This control light burns when tractor is making a left turn and the controller is active. It turns out when the controlling process has been finished.

4.4.2. Control Right Lamp

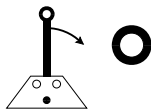

This control light burns when tractor is making a right turn and the controller is active. It turns out when the controlling process has been finished.

4.4.3. Centre Position Lamp

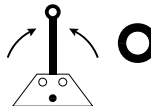

This control light indicates when steering has reached the centre position.

4.4.4. Lock Indication Lamp

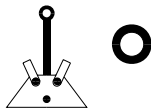

When the TRAIL-Control is switched on, this light indicates if the steering is locked. If the steering is locked, you are unable to switch on the TRAIL-Control.

If the steering is being locked while TRAIL-Control is in working mode, this light is lit shortly before TRAIL-Control switches off itself.

5. Basic Tuning











Before using the implement for the first time or if it doesn't work properly, some basic tuning is necessary. The following describes the steps to carry out the basic tuning.

5.1. Centre Position

5.1.1. Learning centre position

To guarantee the correct trail a fine-tuning of driving straight ahead must be carried out. This way the centre positions of the two potentiometers (tractor and implement) are learned.









Please follow these steps:

1. > press and hold  -key.
> use  - key to switch on the device,
Control lamp in On/Off - key turns on
> wait until control lamp in  -key is off.
> release  -key.
Control lamps turn on in  -key and  -key.
2. > Drive straight ahead with the tractor - implement combination; if possible along a line
> While driving, use manual control turn key  to correct the steering until the implement follows the tractor exactly in its trail.
3. > Wait until control lamp centre position  is on
> press  -key
control lamp in  -key turns off.
> switch the unit off using  -key

5.1.2. Adjust manual control key:

















Normally it is not necessary to adjust the manual control key because this is done in the factory.

When learning of centre position is finished, it is possible to check the centre position of the manual control key. To do so, follow these steps:

1. use  - key to switch the device on.
2. Set  to centre position.
3. Press  key shortly and wait until  is lit.
4. Switch the hydraulics off.
5. Press the  key again. The lamps  and  may not be switched on now.
If this does not happen, turn  key until both lamps are switched off.
6. If necessary the knob of the manual turn key can be adjusted with the following steps.
Remove the red cap.
Loosen the screw underneath, remove the knob and put it on again in the right position.
Screw on tight and replace the red cap.
7. To check the new position, repeat the steps 2 to 6.
8. Switch the Trail-Control off with the  key.

5.2. Learning Final Stops

The mechanical final stop of the steering should be learned by the TRAIL-Control in order for the device to shut off properly. This helps avoiding overheating of the hydraulic system and rough polling of the final stops. Please proceed as follows.

1. > Press and hold  -key.
> Switch the device on using the  -key.
The control lamp in On/Off- -key turns on
> wait until control lamps in  and  -key turn off.
> release  -key.
the control lamp in  -key is on.
> press  -key again. If control lamp flashes, the system is ready to learn the final stops.
2. > turn manual control turnkey  to the right. The steering now moves to the final stop of the right side.
> If the steering is in the utmost final position press the  -key.
> turn manual control turnkey  to the left . The steering now moves to the final stop of the left side.
> If the steering is in the utmost final position press the  -key.
> Turn steering to centre position using the manual control turnkey .
3. > press  -key to escape from tuning mode.
the control lamp in  -key is now continuously on.
> Finally shut off the device using  -key.

5.3. Return to basic tuning









TRAIL-Control contains a basic tuning for your implement that is active when delivered to you. You can alter these data following the procedures above. In case you want to get back your original tuning please follow the instructions below.



WARNING!!

All altered data will be overwritten!!

Please proceed as follows:

- > press and hold -key.
- > Switch on device using -key.
control lamp in -key is on
- > Wait, until control lamps in -key and -key turn off.
- > release -key.
the control lamp in -key flashes.
- > press -key again.
the control lamp in -key turns off.
- > The device switches itself off.

6. Maintenance

6.1. Computer



The computer does not need any maintenance. During winter it should be stored in a well temperatured area







6.2. Sensors

All sensors are free of maintenance.

7. Trouble shooting

Please obey the given order of trouble shooting steps!

Problem	Probable Cause	Fix
Device cannot be switched on	improper polarity of the power supply	Check polarity and change connectors if necessary
	Power supply line broken	Check cable to battery, check battery connectors and melting fuse.
Device turns off immediately after releasing on/off key	Lock is active	Check lock and deactivate if necessary
Implement moves into final position even though controlling is switched on	tractor or implement potentiometer has wrong polarity or connectors to valves are mixed up	please carry out check for controlling in chapter 3.7
	one potentiometer is mechanically defect or not mounted properly	according to chapter 3.4.3 check the sensor and replace if necessary
Trail is not maintained	Manual control turnkey is not in centre position	Turn key into centre position
	Coupling of potentiometer and tractor is broken	Check coupling and replace if necessary
	Basic tuning is improper	Carry out basic tuning
	Too much play between coupler and draw bar	Reduce the play
	Wrong machine type selected	Check the DIP-switches inside the TRAIL-Control unit.
No regulation	Final stops are learned wrong	Learn final stops (chapter 5.2) If this does not help, learn final stops again but change  and  for this procedure.
	Hydraulics switched off or hoses not properly connected	Switch on the hydraulics Check the connection of the hoses
Machine swings over at the end of a curve	The proportional valve is not able to hold against the pressure which a heavy boom may produce	Install a lock valve (see chapter 8.7)
Centre position is not right	Tuning of the implement potentiometer has been altered	Fine-tune centre position

Problem	Probable Cause	Fix
After switching on device all keys are on and the  -key flashes	Processor problem	Return device to manufacturer
After switching on device all keys are on and  lamp flashes.	Memory problem	Return device to manufacturer
After switching on device all keys are on and the  - lamp and  -lamp flash	Faulty data in memory	Return device to manufacturer
After switching on device all keys are on and the  - lamp flashes	Memory read error	Return device to manufacturer
After switching on device all keys are on and the  - lamp and  -lamp flash	Memory write error	Return device to manufacturer

8. Appendix

8.1. Hydraulic System Open Centre

This version must be used for tractors with standard (Open Centre) hydraulics. Also it can be used at tractors with Load Sensing hydraulics. In this case only the TRAIL-Control valve is connected to the tractor. Other functions like boom lift and lower are controlled with a separate valve on the tractor.

It is important that there is no locking screw in the connector “N”. Otherwise the maximum pressure valve in the tractor will open permanently and there will be no proper control.

Attention:

If used at a tractor with load sensing hydraulics, the oil flow should be adjusted to an amount of 30 l/minute. This will prevent heating the oil and reduce the noise.

When using other functions with separate hydraulic valves of the tractor, the TRAIL-Control must be switched off. Otherwise there can be erratic movements of the machine.

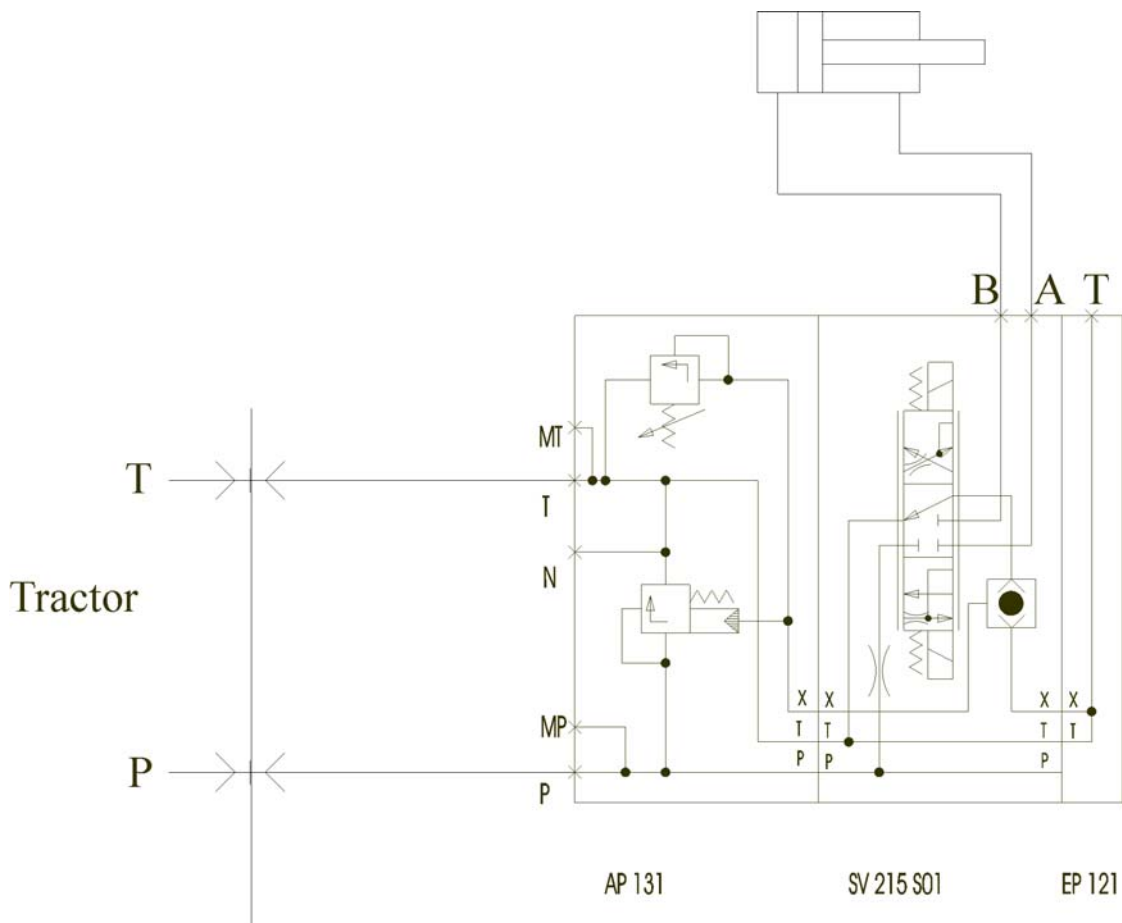

GT 312

8.2. Hydraulic System Open Centre with "N" as Flow Through

This version must be used for tractors with standard (Open Centre) hydraulics. Also it can be used at tractors with Load Sensing hydraulics. In this case only the TRAIL-Control valve is connected to the tractor. Other functions like boom lift and lower are controlled with a separate valve block, which is connected to "N". Important for this version is the locking screw, which has to be mounted in connector "N". If the screw is not mounted there is no oil pressure available at the second hydraulic block. The mounting of the locking screw is described in chapter 8.6.

Attention:

If used at a tractor with load sensing hydraulics, the oil flow should be adjusted to an amount of 30 l/minute. This will prevent heating the oil and reduce the noise.

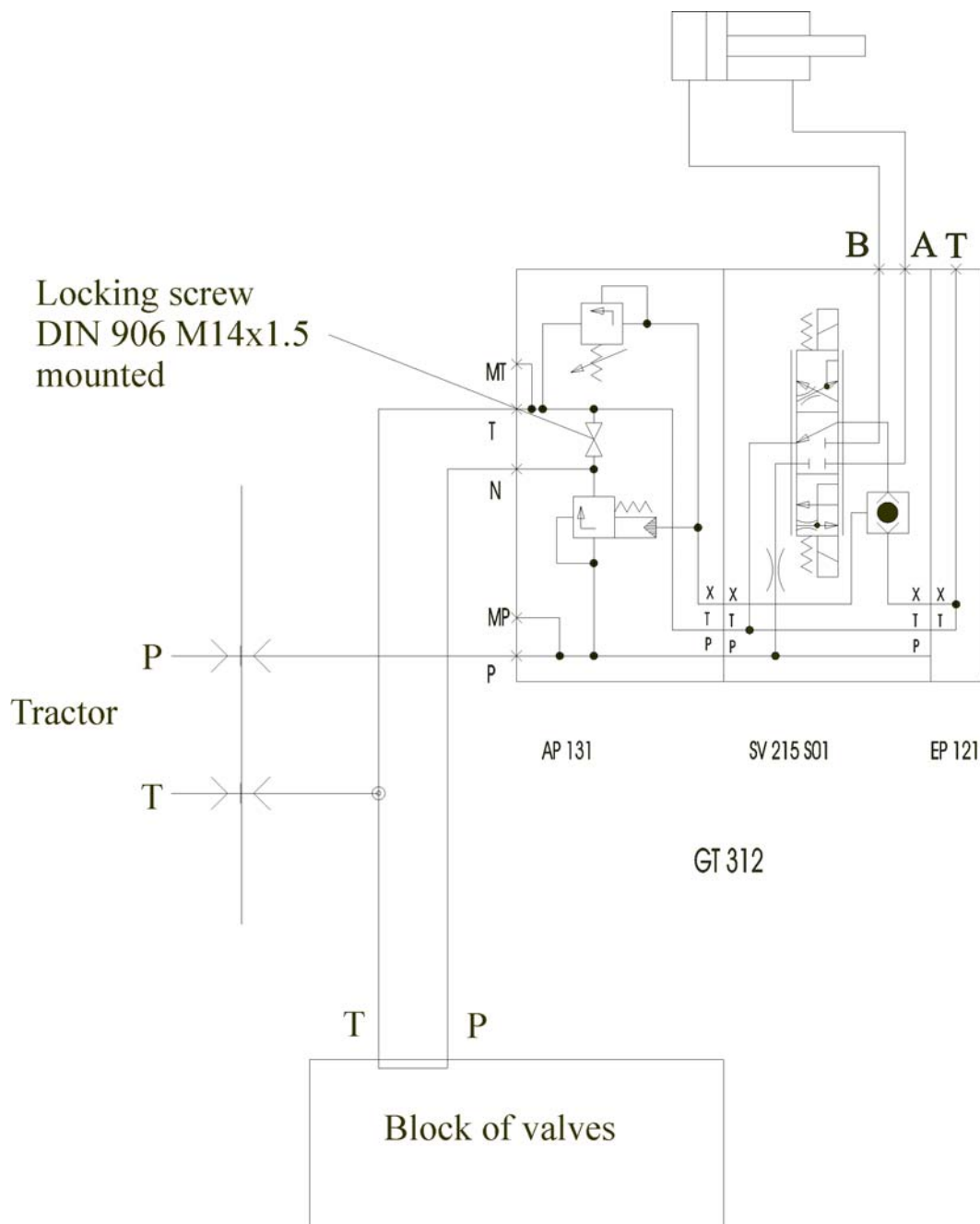

8.3. Hydraulic System Closed Centre

This version must be used for tractors with Closed Centre hydraulics. In this case only the TRAIL-Control valve is connected to the tractor. Other functions like boom lift and lower are controlled with a separate valve on the tractor.

It is important that the locking screw in the connector "N" is mounted.

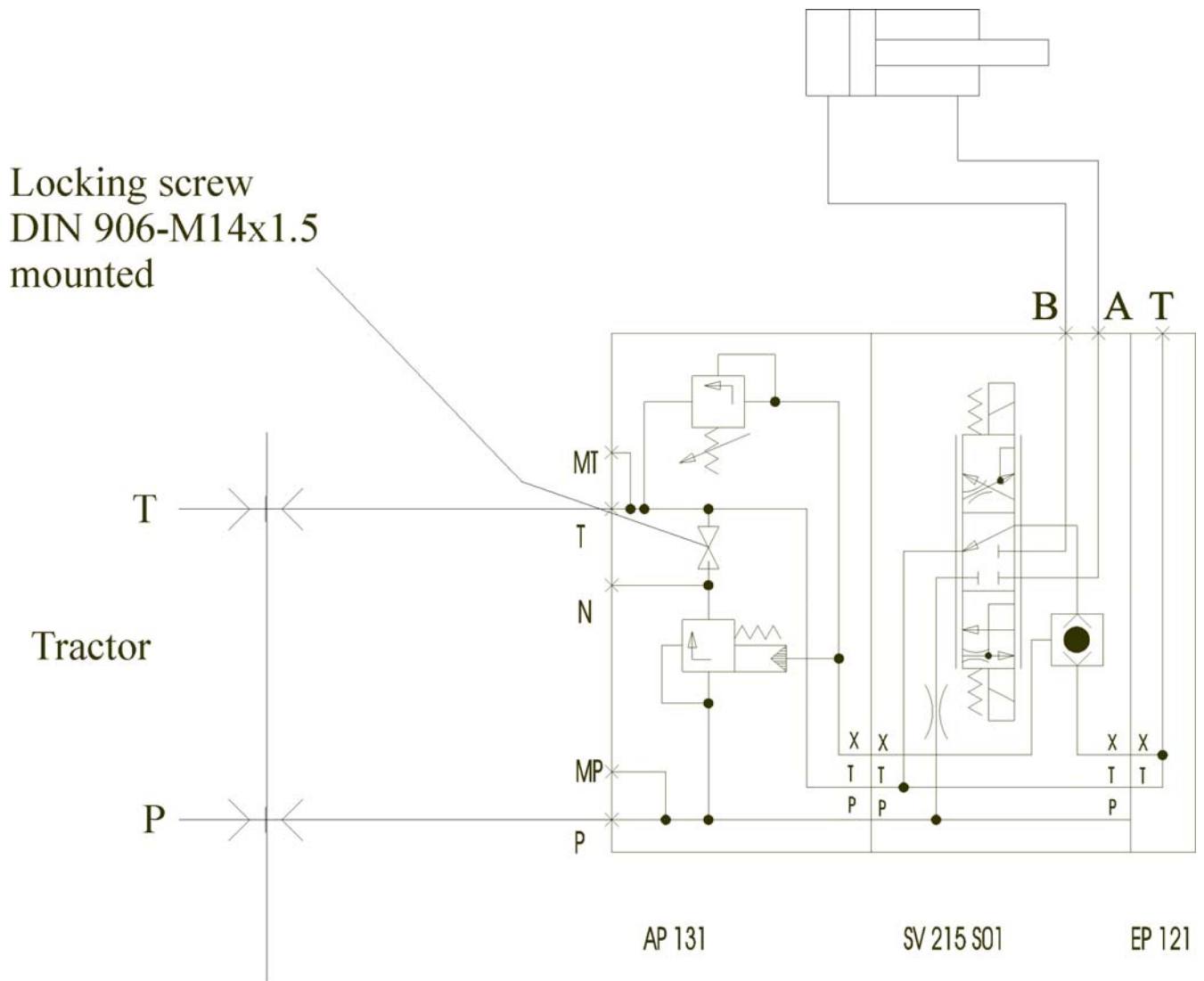

8.4. Hydraulic System Closed Centre and "N" as Flow Through

This version must be used for tractors with Closed Centre hydraulics. In this case the TRAIL-Control valve is connected to the tractor. Other functions like boom lift and lower are controlled with a separate valve block, which is connected to "N". Important for this version is the locking screw, which has to be mounted in connector "N". If the screw is not mounted there is no oil pressure available at the second hydraulic block. The mounting of the locking screw is described in chapter 8.6.

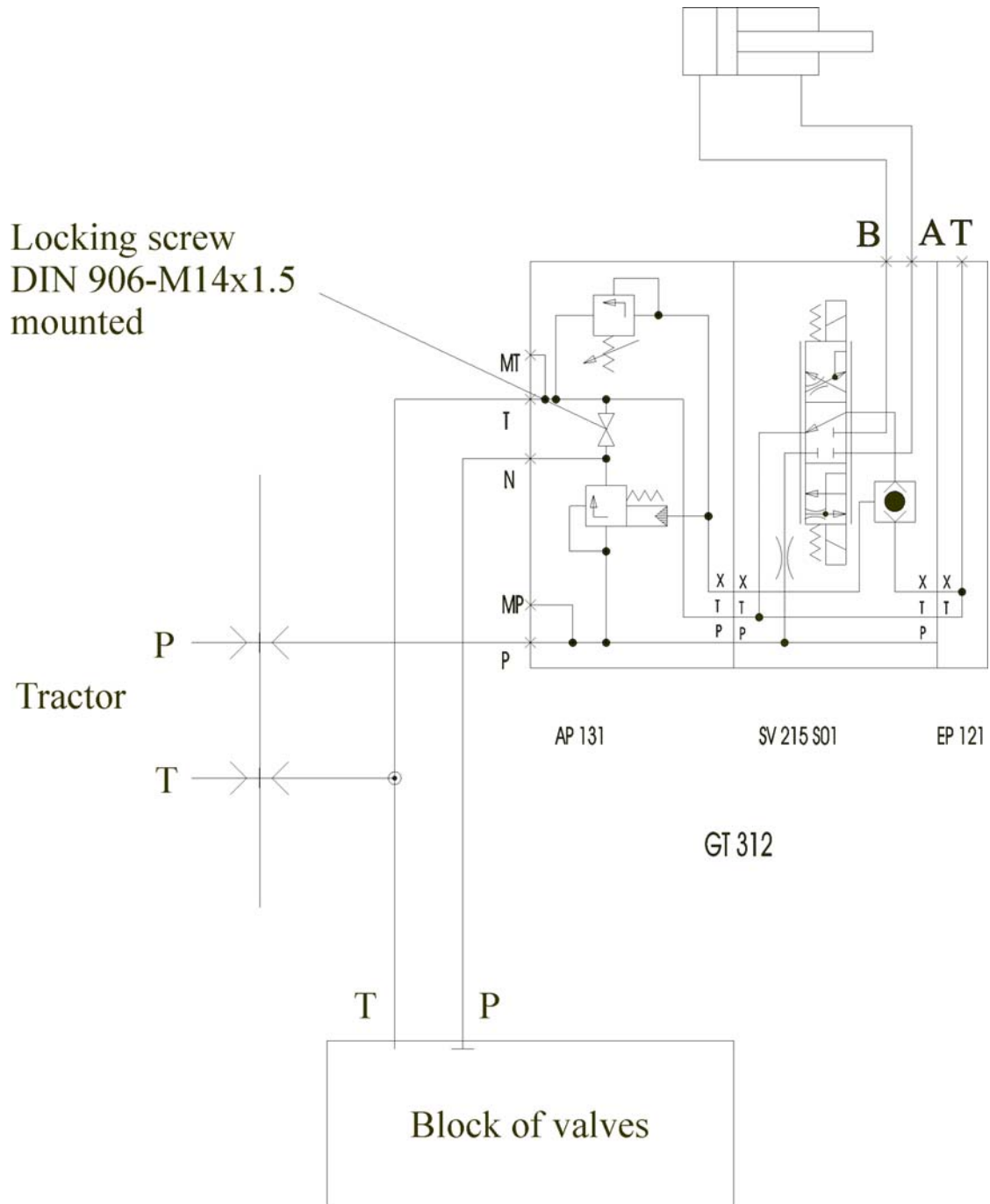

8.5. Hydraulic system Load sensing

This version can be used for tractors with Load Sensing hydraulics. For this the whole system must be prepared for Load Sensing. Otherwise the Open Centre version can be used at a Load Sensing tractor (See chapters 8.1 and 8.2).

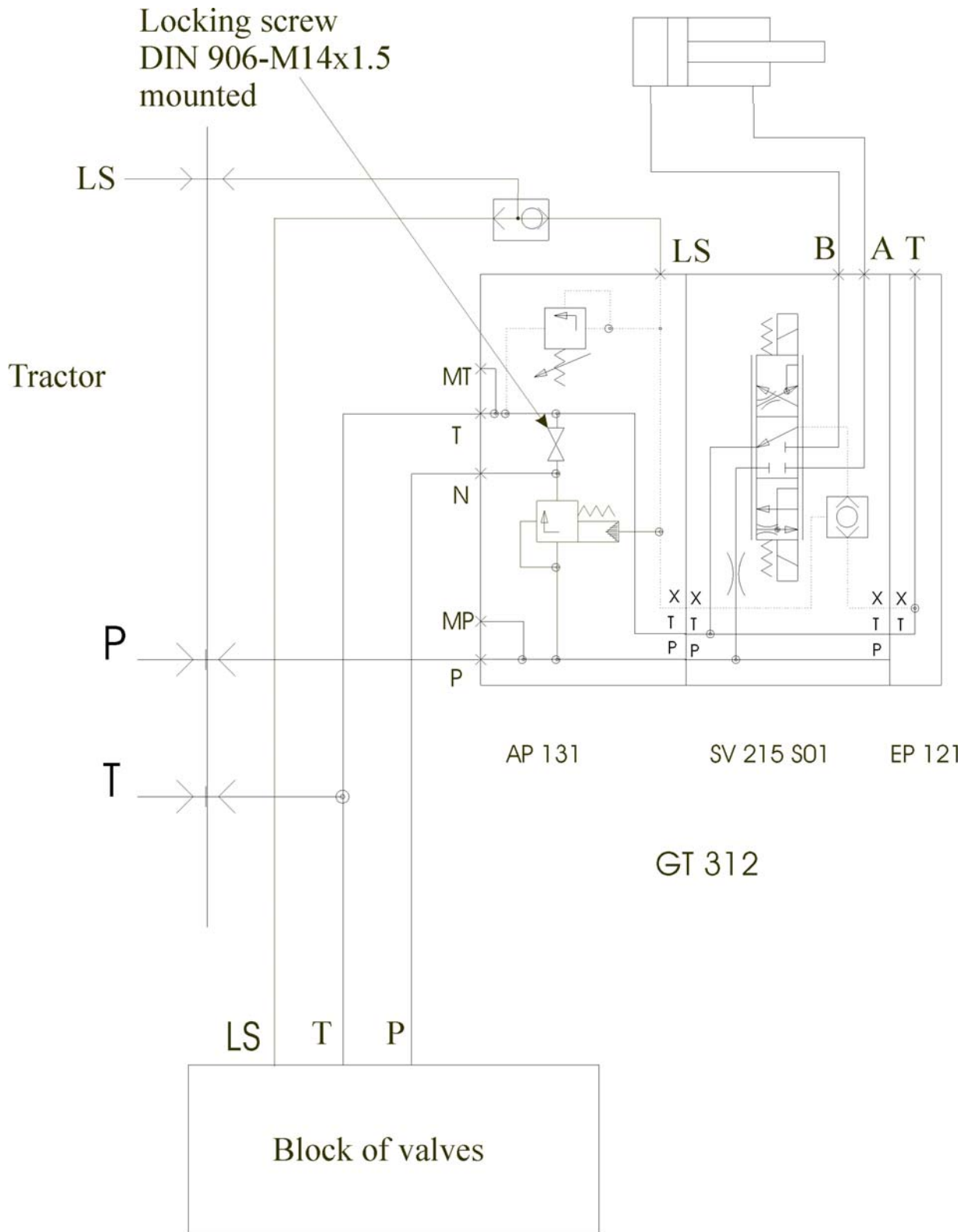

8.6. Locking Screw for Valve

If the input element **AP 131** is being operated with flow through "N" it is necessary to close the connection between "T" and "N" in order for the following systems to have enough pressure. This is being carried out with the help of the locking screw DIN 906 - M14*1,5 St which is included in the package. This locking screw is to be mounted to the connector "N" (see drawing). If no flow through is selected, "N" is being sealed by a screw with a copper washer.

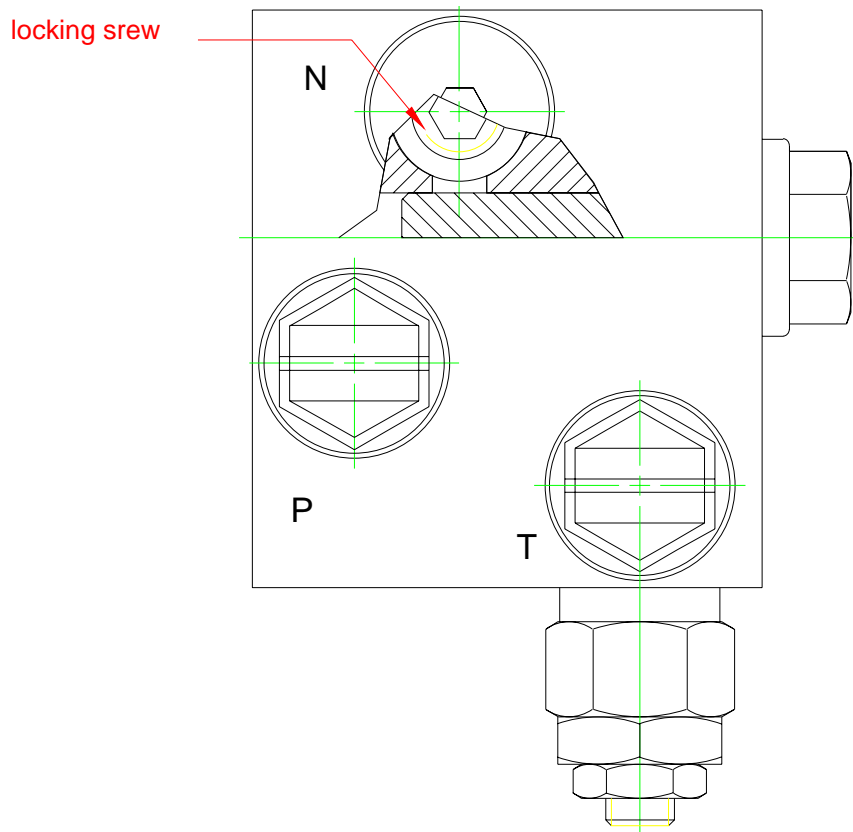

8.7. Lock valve

Working on a slope or with machines with heavy booms a leakage of the proportional valve is possible, when peak loads appear. This problem mainly affects machines with a steering draw bar. In those cases it is recommended to install a lock valve. This valve prevents drifting on a slope and a swing over at the end of a curve with a heavy boom.

Mounting is really easy and can be done supplementary. The lock valve only needs to be fitted between the cylinder and the proportional valve (see drawing).

